



CyberPro PCI 2S

Quick Installation Guide

Introducing the *CyberPro PCI 2S*

The *CyberPro PCI 2S* high-speed serial I/O card provides two additional 9-pin serial ports.

Features and Benefits

- Conforms to PCI v2.2 Plug and Play
- Full support for Windows-based software
- Reduces CPU load and improves system performance dramatically
- IRQ sharing feature reduces IRQ conflicts
- High-speed serial port (9-pin) works with 56K V.90 external modems, ISDN terminal adapters, PDAs, digital cameras, label printers and other serial port devices
- Built-in FIFO buffers dramatically increase data transmit/receive speed, especially under Windows' multitasking environment
- Each serial port can be configured for either 5V or 12V output, for serial devices that require power

System Requirements

- Pentium® or equivalent computer with an available PCI slot
- Windows® 7 (32-/64-bit) / Vista (32-/64-bit) / XP (32-/64-bit) / Server 2003 & 2008 (32-/64-bit) / 2000 / NT 4.0 / ME / 98SE / 98 / 95

Package Contents

- *CyberPro PCI 2S* board
- Driver CD
- Quick installation guide

Layout

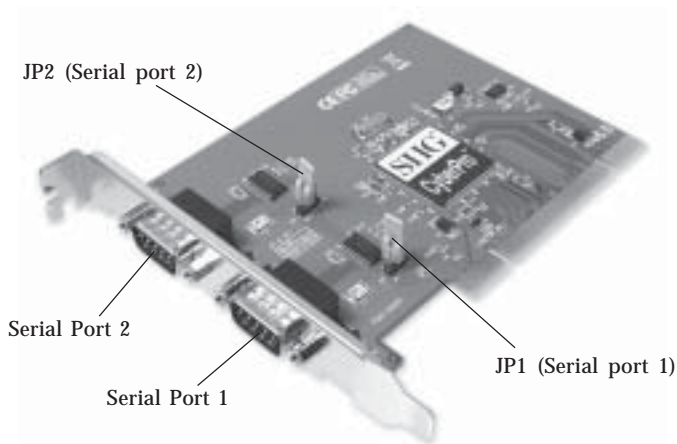

Figure 1. Layout

Jumper Settings (JP1, JP2)

Open = 0 volts (default)

Short 1-2 = 5V

Short 2-3 = 12V

Note: Most serial devices do not require additional power through the serial port. Refer to your serial device's manual for more information.

Hardware Installation

General instructions for installing the card are provided below. Since the design of computer cases and motherboards vary, refer to your computer's reference manual for further information, if needed.

Static Electricity Discharge may permanently damage your system. Discharge any static electricity build up in your body by touching your computer's case for a few seconds. Avoid any contact with internal parts and handle cards only by their external edges.

1. Turn OFF the power to your computer and any other connected peripheral devices.
2. Unplug the power cord from the back of the computer.
3. Remove your computer's cover.
4. Remove the slot bracket from an available PCI slot.
5. Set **JP1** and **JP2** jumper settings to the desired voltage only if your serial device needs additional power from the serial port. However, most serial devices do not require additional power. For more information see **Figure 1** on page **2**. Skip this step if power is not required.
6. To install the card, carefully align the card's bus connector with the selected PCI slot on the motherboard. Push the board down firmly, but gently, until it is well seated.
7. Replace the slot bracket holding screw to secure the card.
8. Replace the computer cover and reconnect the power cord.

Driver Installation

This section provides information on how to install the *CyberPro PCI 2S* drivers.

Windows 7 (32-/64-bit)

1. Right click **Computer**, click **Manage**, click **Device Manager**.
2. Insert the driver CD. Right click **PCI Serial Port**, click **Update Driver Software**.
3. Click **Browse my computer for driver software**.
4. Type **D:**, then click **Next**. (Change **D:** to match your CD/DVD-ROM drive letter)
5. At Windows has successfully updated your driver software, click **Close**.
6. Right click **Other PCI Bridge Device**, click **Update Driver Software**.
7. Repeat steps 3-5.
8. Right click **CyberSerial Communication Port**, click **Update Driver Software**.
9. Click **Browse my computer for driver software**.
10. Type **D:**, click **Next**. (Change **D:** to match your CD/DVD-ROM drive letter)
11. At Windows has successfully updated your driver software, click **Close**.
12. Repeat steps 8-11 to complete the installation.

Windows Vista™ (32-/64-bit)

1. At the **Found New Hardware** window, insert the driver CD, click **Locate and install driver software (recommended)**, then click **Continue**.
2. Click **Next**, then click **Close**.

3. Repeat step 2 to complete the driver installation.

Note: Windows Vista driver installation process may take several minutes to complete.

Windows XP (32-/64-bit) / Server 2003 (32-/64-bit)

1. At the **Found New Hardware Wizard**, insert the driver CD.
2. Select **No, not this time**, click **Next**. (Skip this step if not prompted)
3. Select **Install the software automatically (Recommended)**, then click **Next**.
4. Click **Finish**.
5. Repeat steps 1-4 two more times.
6. Restart Windows to complete the installation.

Windows Server 2008 (32-/64-bit)

1. At the **Found New Hardware Wizard**, click **Locate and install driver software (recommended)**.
2. Insert the driver CD.
3. Click **Don't search online**.
4. Click **I don't have the disc. Show me other options**.
5. Click **Browse my computer for driver software (advanced)**.
6. Type **D:**, then click **Next**. (Change **D:** to match your CD/DVD-ROM drive letter)
7. At **The software for this device has been successfully installed**, click **Close**.
8. Repeat steps 3-7 to complete the installation.

To Verify Windows 7 / Vista / XP / Server 2003 & 2008 Installation

1. Check in Device Manager to verify installation.
For Windows 7: Right click **Computer**, click **Manage**, then click **Device Manager**.
For Windows Vista: Right click **Computer**, click **Manage**, click **Continue**, then click **Device Manager**.
For XP / Server 2003: Right click **My Computer**, click **Manage**, then click **Device Manager**.
For Server 2008: Right click **Computer**, click **Manage**, double click **Diagnostics**, then click **Device Manager**.
2. Click on the + (plus sign) in front of **Ports (COM & LPT)**, **CyberSerial 16Cxxx...** should be displayed two times.
3. Double click **Multifunction adapters, SIIG CyberPro 2S board** should be displayed.

Windows 2000

1. At the **Found New Hardware Wizard**, click **Next**.
2. Select **Search for a suitable driver for my device (recommended)**, then click **Next**.
3. Check **Specify a location**, uncheck the other boxes, then click **Next**.
4. Insert the driver CD, type in **D:\2000**, then click **OK**. (Change **D:** to match your CD-ROM drive letter)
5. Click **Next** and **Finish**.
6. Repeat steps 1-5 two more times.
7. Restart Windows to complete the installation.

To Verify Windows 2000 Installation

1. Right click **My Computer**, click **Manage**, then click **Device Manager**.
2. Click on the + (plus sign) in front of **Ports (COM & LPT)**, **CyberSerial 16Cxxx...** should be displayed two times.
3. Double click **Multifunction adapters**, **SIIG CyberPro 2S board** should be displayed.

Windows ME

1. At the **Add New Hardware Wizard**, select **Specify the location of the driver (Advanced)**, then click **Next**.
2. Insert the driver CD, check **Specify a location**, uncheck the other box, type in **D:\ME**, then click **Next**. (Change **D:** to match your CD/DVD-ROM drive letter)
3. Click **Next**, then **Finish**.
4. Repeat steps **1** and **2**.
5. Click **Next**, **Next**, then **Finish**.
6. Restart Windows to complete the installation.

Windows 98/98SE

1. At the **Add New Hardware Wizard**, click **Next**.
2. Select **Search for the best driver for your device (Recommend)**, then click **Next**.
3. Insert the driver CD, check **Specify a location**, uncheck the other boxes, type in **D:\9x**, then click **Next**. (Change **D:** to match your CD/DVD-ROM drive letter)
4. Click **Next**, then **Finish**.

5. Repeat steps 1-4.
6. Restart Windows to complete the installation.

Windows 95

1. At the **Update Device Driver Wizard**, click **Next**.
2. Insert the driver CD, click **Other Locations**.
3. Type in **D:\9x**, click **OK**, then click **Finish**. (Change **D:** to match your CD/DVD-ROM drive letter)
4. From the **Insert Disk** window, click **OK**. When the **Copying Files** dialog box pops up, type in **D:\9x**, then click **OK**. (Change **D:** to match your CD/DVD-ROM drive letter)
5. Restart Windows to complete the installation.

To Verify Windows ME / 98SE / 98 / 95 Installation

1. Right click **My Computer**, click **Properties**, then click **Device Manager**.
2. Double click **Ports (COM & LPT)**, **CyberSerial PCI 16Cxxx...** should be displayed two times.
3. Double click **Multi-function adapters**, **SIIG CyberPro 2S...** and **PCI Function** should be displayed.

Windows NT 4.0

1. From the desktop click **Start**, then **Run**.
2. Insert the driver CD, type in **D:\NT4\Install_serial.exe**, then click **OK**. (Change **D:** to match your CD/DVD-ROM drive letter)
3. Click **Next** when the **Welcome** window appears.
4. Select **Install**, then click **Next**.

5. Click **Yes**, then click **Exit**.
6. Restart Windows to complete the installation.

To Verify Windows NT 4.0 Installation

1. Click **Start, Settings, Control Panel**. Double click **Ports** device icon.
2. Two new **COM** ports will be assigned when successfully installed.

Changing COM Port Address

Some serial devices need a specific COM port in order to work. If your serial device works properly, do not change this setting.

Windows 7 / Vista / XP / Server 2003 & 2008 / 2000

1. From the **Device Manager** window double click **Ports (COM & LPT)**, then double click the **CyberSerial** serial port you want to change.
2. Click **Settings** tab and click **Advanced**.
3. Click the down arrow that is next to the **COM Port number** box and select a COM port that is not in use. Click **OK**.
4. Click **OK**, then close **Device Manager** to save the changes.

Windows ME / 98SE / 98 / 95

1. From the **Device Manager** window double click **Ports (COM & LPT)**, then double click the **CyberSerial PCI** serial port you want to change.
2. Click **Settings** tab, click the down arrow that is next to the **Port Name** box and select a COM address that is not currently in use.
3. Click **OK**, then close **Device Manager** to save the changes.

Technical Support and Warranty

QUESTIONS? SIIG's **Online Support** has answers! Simply visit our web site at www.siig.com and click **Support**. Our online support database is updated daily with new drivers and solutions. Answers to your questions could be just a few clicks away. You can also submit questions online and a technical support analysts will promptly respond.

SIIG offers a lifetime manufacturer warranty with this product. Please see our web site for more warranty details. If you encounter any problems with this product, please follow the procedures below.

A) If it is within the store's return policy period, please return the product to the store where you purchased from.

B) If your purchase has passed the store's return policy period, please follow these steps to have the product repaired or replaced.

Step 1: Submit your RMA request.

Go to www.siig.com, click **Support**, then **RMA** to submit a request to [SIIG RMA](#). If the product is determined to be defective, an RMA number will be issued.

Step 2: After obtaining an RMA number, ship the product.

- Properly pack the product for shipping. All software, cable(s) and any other accessories that came with the original package must be included.
- Clearly write your RMA number on the top of the returned package. SIIG will refuse to accept any shipping package, and will not be responsible for a product returned without an RMA number posted on the outside of the shipping carton.
- You are responsible for the cost of shipping. Ship the product to the following address:

SIIG, Inc.

6078 Stewart Avenue

Fremont, CA 94538-3152, USA

RMA #: _____

- SIIG will ship the repaired or replaced product via Ground in the U.S. and International Economy outside of the U.S. at no cost to the customer.

About SIIG, Inc.

Founded in 1985, SIIG, Inc. is a leading computer upgrade manufacturer of I/O connectivity products, including PCIe, PCI & ISA serial and parallel ports, USB, Serial ATA & UltraATA controllers, FireWire (1394a/b), networking, sound cards, and other accessories. SIIG is the premier one-stop source of upgrades.

SIIG products offer comprehensive user manuals, many user-friendly features, and are backed by an extensive manufacturer warranty. High-quality control standards are evident by the overall ease of installation and compatibility of our products, as well as one of the lowest defective return rates in the industry. SIIG products can be found in computer retail stores, mail order catalogs, through major distributors, system integrators, and VARs in the Americas and the UK, and through e-commerce sites.

PRODUCT NAME

CyberPro PCI 2S

FCC RULES: TESTED TO COMPLY WITH FCC PART 15, CLASS B OPERATING ENVIRONMENT: FOR HOME OR OFFICE USE

FCC COMPLIANCE STATEMENT:

This device complies with part 15 of the FCC Rules. Operation is subject to the following two conditions: (1) This device may not cause harmful interference, and (2) this device must accept any interference received, including interference that may cause undesired operation.

THE PARTY RESPONSIBLE FOR PRODUCT COMPLIANCE

SIIG, Inc.
6078 Stewart Avenue
Fremont, CA 94538-3152, USA
Phone: 510-657-8688

CyberPro PCI2S is a trademark of SIIG, Inc. SIIG and the SIIG logo are registered trademarks of SIIG, Inc. Microsoft, Windows and Windows Vista are either registered trademarks or trademarks of Microsoft Corporation in the United States and/or other countries. Pentium is a registered trademark of Intel Corporation. Other names used in this publication are for identification only and may be trademarks of their respective companies.